



**Dunnville Drinking Water System  
2024 Annual Water Quality Report  
January 1, 2024 – December 31, 2024**

# Table of Contents

<b>Quality Management System Policy</b> .....	<b>2</b>
Haldimand County Quality Management System Summary .....	3
<b>Dunnville Drinking Water System</b> .....	<b>4</b>
Dunnville Drinking Water System Overview .....	5
Expenditure Information .....	6
<b>Multi-Barrier Approach</b> .....	<b>7</b>
<b>Water Sampling</b> .....	<b>8</b>
Microbiological Sampling .....	8
Operational Sampling.....	9
Hardness.....	10
Lead Sampling .....	11
Organic Sampling.....	11
<b>Water Use</b> .....	<b>13</b>
Raw Water .....	13
Potable Water .....	15
<b>Regulatory Compliance</b> .....	<b>16</b>
Adverse Water Quality Incidents .....	16
Annual Drinking Water Inspection .....	16
Dunnville Drinking Water System – DWS# 220003555.....	17
<b>Report Availability</b> .....	<b>18</b>
<b>Appendix A</b> .....	<b>19</b>
Inorganic Parameters.....	19
Organic Parameters .....	20
Microcystin Sample Results .....	21

# Quality Management System Policy

The Corporation of Haldimand County owns, maintains and operates various drinking water systems. Haldimand County is committed to:

- Ensuring our drinking water systems comply with all current legislation and regulatory requirements for the safe supply of drinking water;
- Ensuring financial support is provided to maintain infrastructure integrity to allow safe and consistent delivery of drinking water to our water customers;
- Reviewing, maintaining and continually improving our Quality Management System and to communicate the Plan with our water customers.



## Haldimand County Quality Management System Summary

Haldimand County's Quality Management System (QMS) is legislated under the Drinking Water Quality Management Standard (DWQMS) through the Safe Drinking Water Act. To maintain operating authority accreditation, the Ministry of the Environment, Conservation and Parks (MECP) mandate tasks that must be completed annually. These activities include:

- Conducting an internal audit of the Quality Management System.
- Conducting a Management Review meeting.
- Participating in an external audit conducted by a third-party Accreditation Body.
- Updating the Quality Management System Operational Plan.
- Updating Council of the status of the County's Quality Management System.

The QMS Operational Plan was reviewed and updated in 2024, with focus on Document and Records Control (Element 5), conforming to the DWQMS standards and Continual Improvement (Element 21) all while incorporating organizational changes within the County.

Internal audits were completed with support from Environmental Operations staff. Extra support from other County staff during internal audits would increase the coverage to ensure the system is conforming and efficient. The audit report did note three minor non-conformances and several opportunities for improvement.

Haldimand County must receive accreditation annually to operate the water distribution systems. Through a qualified third-party auditor, the County must demonstrate that its QMS (Quality Management System) meets the requirements of the DWQMS (Drinking Water Quality Management Standard). Intertek conducted a re accreditation audit on February 28 and 29, 2024. The County received three minor non-conformances. These were deemed to be minor and administrative in nature with no immediate risk to the drinking water system. Root cause analysis was conducted and preventative actions were developed to ensure the non-conformances will not occur in the future. Haldimand County received re-accreditation May 31, 2024.

Intertek performed the annual systems audit September 12, 2024 which resulted in four opportunities for improvement. Any non-conformance or opportunity for improvement is added to the corrective action process.

Staff are required to conduct an annual Management Review meeting to evaluate the effectiveness of the QMS. Deficiencies and opportunities for improvement are identified and action items are developed to ensure follow-up. The County held their Management Review meeting on October 31, 2024 with the second meeting on December 20, 2024.

As part of the agreement with the County and through the regulations, Ontario Clean Water Agency (OCWA) must obtain accreditation to operate the water treatment facilities on behalf of the County. In 2024 OCWA continued full scope accreditation under the requirements of DWQMS.

# Dunnville Drinking Water System

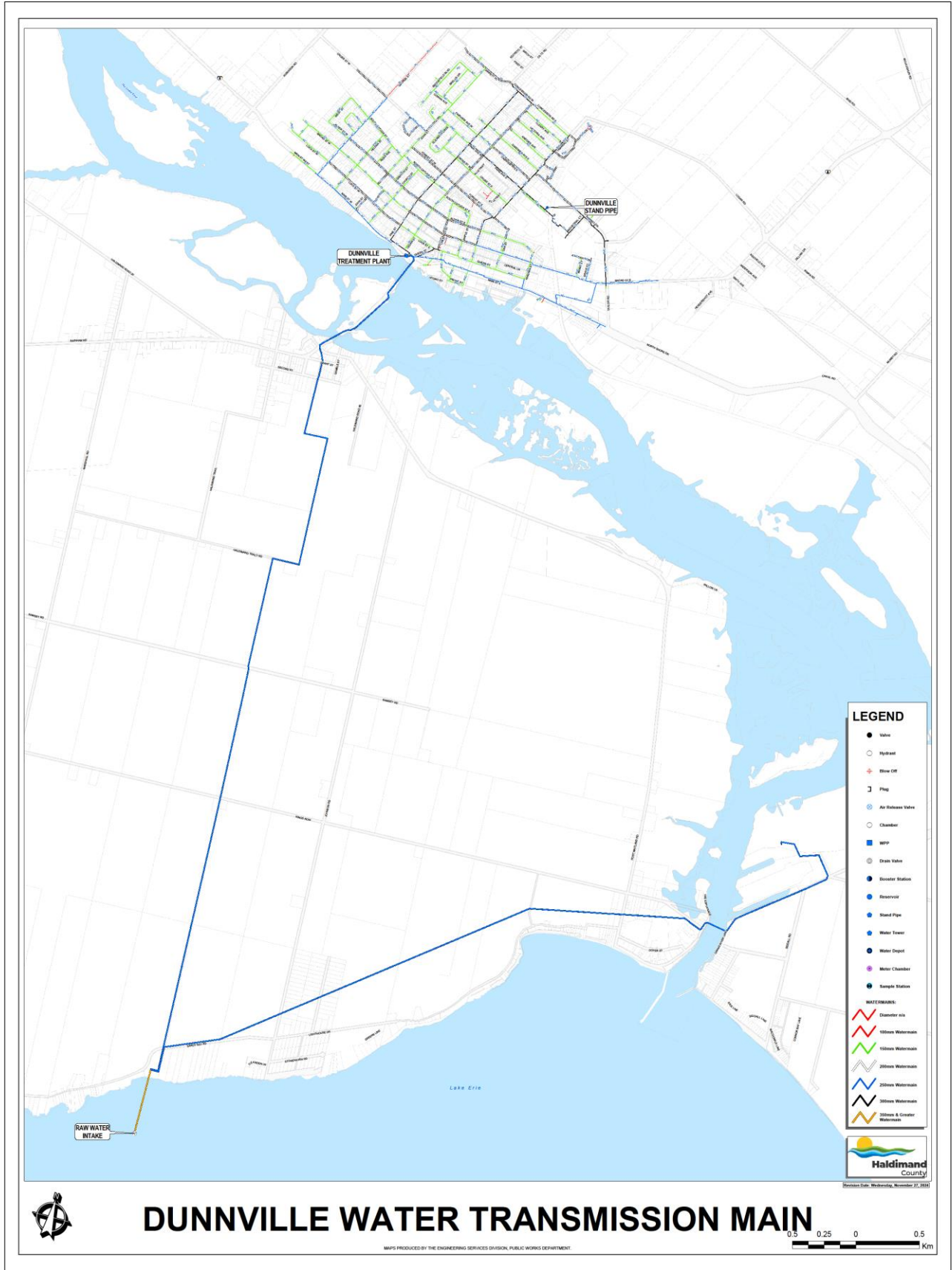

# Dunnville Drinking Water System Overview

The Dunnville Drinking Water System’s primary raw water source is Lake Erie. Raw water is drawn into the Port Maitland Low Lift Pumping Station where it can be pre-chlorinated with sodium hypochlorite for zebra mussel control. Raw water is then pumped through approximately ten kilometers of raw water transmission watermain to the Dunnville Water Treatment Plant. Raw water is also supplied to industrial users in Port Maitland.

There is also a raw water intake located in the Grand River. This raw water source has not been used to supply the treatment plant since the early 2000’s, however it is available for use in an emergency situation.

The Dunnville Water Treatment Plant is a conventional water treatment plant with a rated capacity of 14,500 m<sup>3</sup>/day. A coagulant (Aluminum Sulphate was used in 2024) is injected into raw water and undergoes flash mixing. Water then flows through a series of flocculation and sedimentation tanks to five dual media filters containing sand and granular activated carbon. Following filtration, the water is disinfected with sodium hypochlorite and stored in two reservoirs. High lift pumps deliver potable water to the Dunnville Water Distribution System.

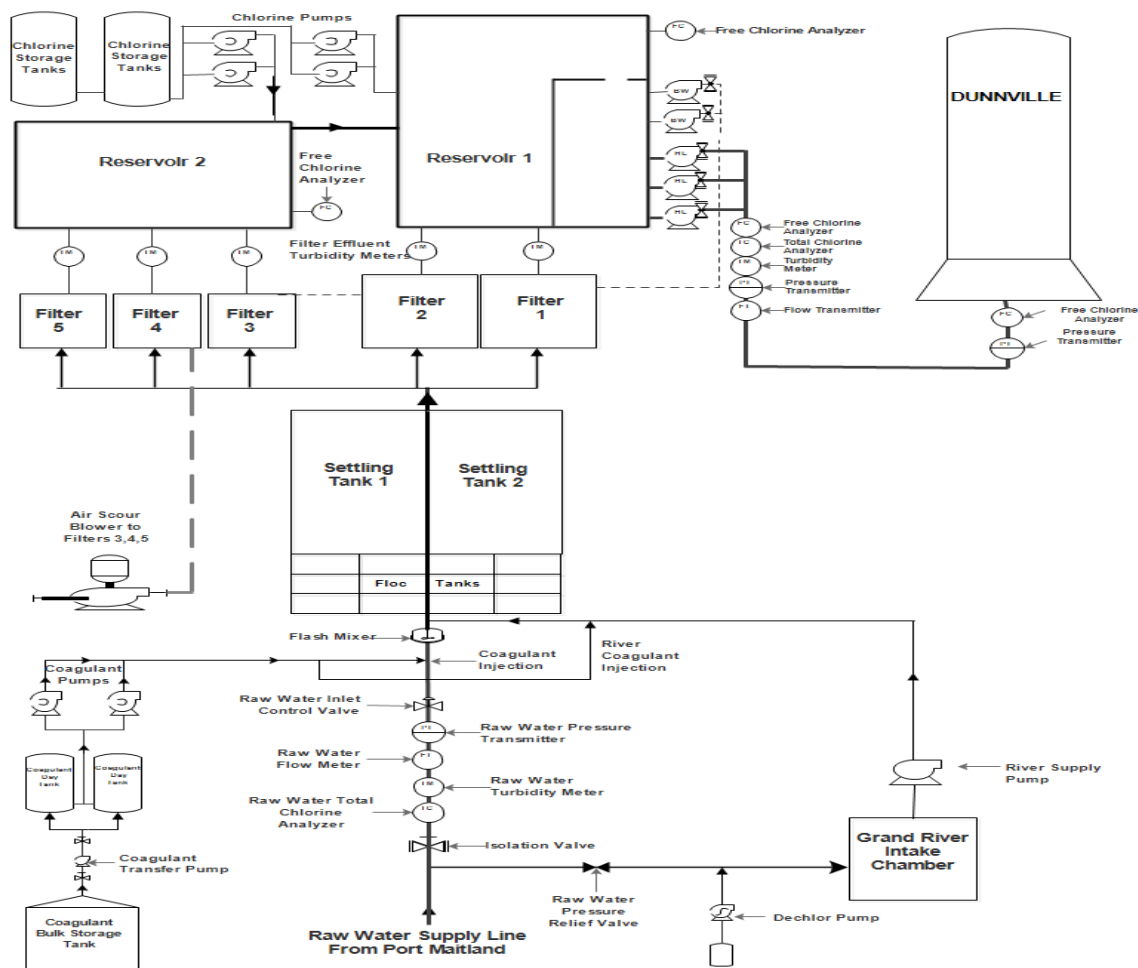

Figure 1: Dunnville Water Treatment Plant Schematic

The water distribution system utilizes a standpipe for storage and to maintain water pressure. A bulk water depot provides potable water to rural residents and bulk water haulers.

The distribution system infrastructure services approximately 5,907 people (2021 Census).

Ontario Clean Water Agency operates and maintains the raw water transmission mains, low lift pumping station, water treatment plant, and the standpipe. Haldimand County operates and maintains the distribution system, including the bulk water depots.

## Expenditure Information

Haldimand County and its contract operators are diligent in prioritizing projects on an annual basis to eliminate unnecessary expenditures. Using the best available information at the time of this report, expenses incurred in the Dunnville Drinking Water System for 2024 are identified in Table 1. All drinking water expenditure information is not included in this report.

**Table 1: Dunnville Drinking Water System 2024 Expenditures**

Dunnville Raw Water Supply Valve and Chamber Refurb	\$ 225,000
Dunnville WTP Upgrades	\$ 1,022,744
Dunnville Standpipe Building Roof Repairs	\$ 1,656
WTP PLC Replacements	\$16,530
<b>Total Cost:</b>	<b>\$ 1,265,930</b>

# Multi-Barrier Approach

Through the Walkerton Inquiry, Justice O'Connor recommended that drinking water is best protected by taking an approach that uses multiple barriers to prevent contamination from affecting our drinking water. The multi-barrier approach addresses potential threats by ensuring barriers are in place to either eliminate or minimize their impact. This holistic approach recognizes that each barrier may not be able to completely remove a contaminant, but by working together the barriers provide a high-level of protection. Typical barriers include:

## Source Protection

- **Source Protection Plans**
- **Treatment**
  - **Treatment and Disinfection Goals**
- **Distribution System**
  - **Chlorine Residual Maintenance**
- **Monitoring**
  - **Sampling Programs**
- **Emergency Preparedness**
  - **Emergency Plans**



Haldimand County has adopted the multi-barrier approach in ensuring safe, reliable drinking water. Figure 2 shows how administration, design, maintenance, and operation work together to establish and maintain multi-barrier protection (US EPA, 1998).

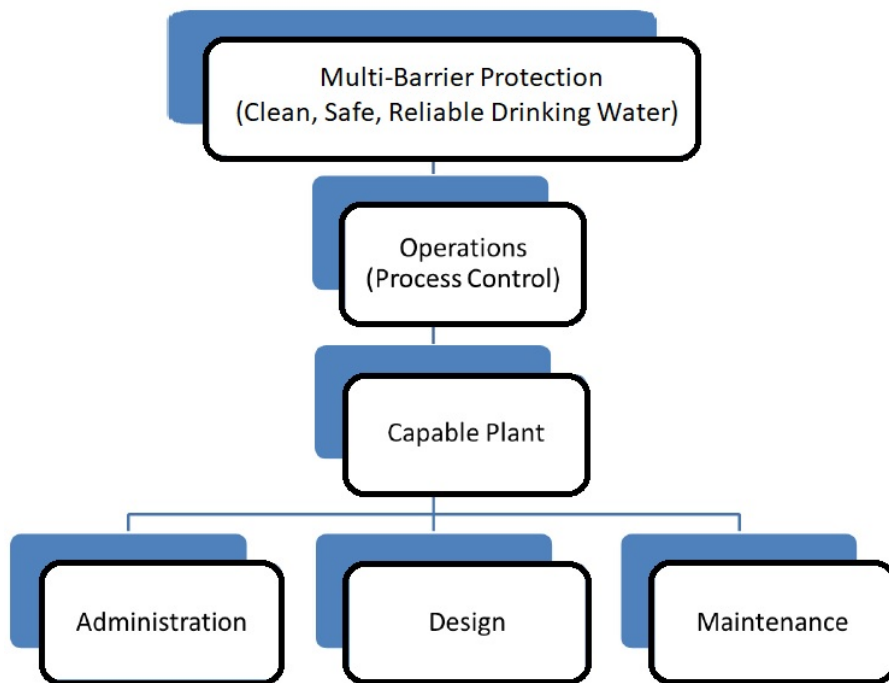

**Figure 2: Responsibilities for Clean, Safe and Reliable Drinking Water**



A description of the responsibilities in each area is summarized as follows:

- **Administration:** The administrators or managers of a water treatment system are responsible for providing the resources (budget and staff) and policies (hours of staffing, reporting requirements, training and certification requirements, etc.). Funding may also need to be justified and obtained if the design of a system is inadequate or major upgrades are required. Managers establish and maintain emergency response plans and communication procedures to ensure prompt response to unsafe drinking water.
- **Design:** The designer's responsibility is to provide the physical infrastructure (pipes, valves, tanks, meters, etc.) capable of reliably producing and distributing the quality and quantity of water required. The design must provide adequate flexibility and controllability to enable the operator to make appropriate adjustments.
- **Maintenance:** The system must be maintained in good working order with the key equipment functional at all times. Should a key piece of equipment break down then it should be repaired in a timely manner.
- **Operations:** Once a capable system is in place, then it is the operator's responsibility to deliver safe drinking water through monitoring, testing and process control (for example by changing the setting on the dosing pumps). Operators are also responsible for maintaining records (log books, data forms, etc.), which aid in troubleshooting and design of upgrades. A further, and commonly unrecognized responsibility of the operator is to communicate the needs of the facility to administrators for possible action.

## Water Sampling

To comply with drinking water legislation, drinking water systems are required to monitor their water quality. Haldimand County has committed to providing safe, reliable drinking water and is diligent in ensuring that sampling and monitoring programs effectively characterize water quality. All samples are taken by certified operators and tests performed by accredited, licensed laboratories.

## Microbiological Sampling

Microbial quality is one of the primary indicators for the safety of a drinking water supply. Of all contaminants in drinking water, human and/or animal feces present the greatest danger to public health. Pathogenic or disease-causing micro-organisms (including certain protozoa, bacteria or viruses) may be found in untreated water supplies. Bacteriological monitoring and testing are a way to detect and control pathogenic bacteria in treated drinking water supplies. Heterotrophic Plate Count (HPC) samples are monitored to identify potential changes in water quality and are not used as an indicator of adverse human health effects. Table 2 provides a summary of microbiological sampling completed in the Dunnville Drinking Water System during 2024.

**Table 2: 2024 Dunnville Drinking Water System Microbiological Sampling**

	Number of Samples	Range of E.coli Results (cfu/100ml)	Range of Total Coliform Results (cfu/100ml)	Number of HPC Samples	Range of HPC Results (cfu/ml)	Number of Background Samples	Range of Background Results (cfu/ml)
Raw – Lake Erie	53	0– 920	2– 46000	N/A	N/A	N/A	N/A
Raw at WTP	53	1-100	0 – 88000	N/A	N/A	N/A	N/A
Raw – Grand River	53	2 – 5000	50 - 54000	N/A	N/A	N/A	N/A
Treated	159	0	0	159	0 - 110	159	0
Distribution System	196	0	0	49	0 - 2	196	0 - 8
Dunnville Standpipe	53	0	0	53	0-10	53	0

\*Note: At a minimum, 25% of all drinking water samples must be analyzed for HPC.

### Operational Sampling

Operational sampling and monitoring are important in maintaining the integrity of each barrier in the multi-barrier approach. Schedule 7 and 8 of Ontario Regulation 170/03 specify requirements for operational checks that municipalities must follow. Table 3 provides a summary of operational samples taken for the drinking water system. Regulatory requirements were consistently achieved for filtered water turbidity and efforts continue to consistently achieve recommended settled and filter targets. Disinfection regulatory requirements and operational targets were consistently achieved in 2024.

**Table 3: 2024 Dunnville Drinking Water System Operational Sampling**

	Number of Grab Samples	Range of Results (mg/L)	Regulatory Requirement	Recommended Target
Raw Turbidity	8784	1.09 - 160	N/A	N/A
Settled Turbidity	8784	0 - 3.02	N/A	2.00 NTU
Filter Turbidity	8784	0.018 – 0.095	≤ 0.30 in 95% of all monthly readings	0.10 NTU
Treated Turbidity	8784	0.01 – 0.055	N/A	≤ 5.00 NTU
Free Chlorine High Lift	8784	0.97 – 1.79	≥ 0.05 mg/L	≥ 0.20 mg/L
Free Chlorine Distribution System	366	0.45 - 1.55	≥ 0.05 mg/L	≥ 0.20 mg/L
Dunnville Standpipe	53	0.68 – 1.35	> 0.05 mg/L	> 0.20 mg/L

\*Note: 8784 is used for continuous monitoring (24 samples per day \* 366 days/year (2024 being a leap year)).

## Hardness

As result of public inquiries, a treated water hardness sampling program was initiated.

The term hardness was originally applied to waters that were hard to wash in, referring to the soap wasting properties of hard water. Hardness prevents soap from lathering by causing the development of an insoluble curdy precipitate in the water; hardness typically causes the buildup of hardness scale (such as seen in cooking pans). Dissolved calcium and magnesium salts are primarily responsible for most scaling in pipes and water heaters and can cause numerous problems in laundry, kitchen, and bath. Hardness is usually expressed in grains per gallon (or ppm) as calcium carbonate equivalent.

The degree of hardness standard as established by the American Society of Agricultural Engineers (S-339) and the Water Quality Association (WQA) is shown in the following table:

**Table 4: Standard Degree of Hardness**

Degree of Hardness	Grains per Gallon (gpg)	Ppm (mg/L)
Soft	< 1.0	< 17.0
Slightly Hard	1.0 – 3.5	17 - 60
Moderately Hard	3.5 – 7.0	60 - 120
Hard	7.0 – 10.5	120 - 180
Very Hard	> 10.5	> 180

The sample results in Table 5 indicate that the average value for Dunnville is considered to have hard water as taken from the Degree of Hardness Table above.

**Table 5: 2024 Dunnville Drinking Water System Hardness Sampling**

**Parameter Total Hardness (mg/L as CaCO<sub>3</sub>)**

Sample Date	Dunnville
February 20, 2024	129
May 7, 2024	144
July 16, 2024	126
November 5, 2024	128
<b>2024 Average -----&gt;</b>	<b>132</b>

## Lead Sampling

The community lead testing program is a requirement of O. Reg. 170/03 under the Safe Drinking Water Act, 2002. Haldimand County is exempt from sampling private residences due to having less than 10% of plumbing sample locations exceed the standard for two consecutive periods of reduced sampling. Annual pH and alkalinity samples are taken, as well as distribution system lead samples, every three years. There are no regulatory limits for alkalinity and pH, however Haldimand County sample results are within the operational guidelines provided by the MECP. A summary of 2024 sampling has been provided in Table 6.

**Table 6: 2024 Dunnville Drinking Water System Lead Sampling**

Location Type	Number of Samples	Range of Results (min) – (max)	Number of Exceedances
Distribution - Lead	0	N/A	0
Distribution - pH	6	7.15 - 7.32	N/A
Distribution - Alkalinity	6	75 – 86 mg/L	N/A

## Organic Sampling

To protect drinking water from pathogens, a disinfectant (usually chlorine) is added to the drinking water. Disinfectants can react with naturally-occurring materials in the water to form disinfection byproducts (DBP), which may pose health risks.



A challenge for water systems is balancing pathogen control and disinfection byproduct formation. It is important to provide protection from pathogens while minimizing health risks from disinfection byproducts. More information on each byproduct is summarized in Table 7.

Haldimand County sample for haloacetic acids (HAA) and trihalomethanes (THM) at the water treatment plant and in the distribution system where there is an elevated potential for the formation of these byproducts. Although a treatment sample is not required by regulation, the sample is used to monitor byproduct formation within the drinking water system.

**Table 7: Disinfection Byproduct Information**

<b>Disinfection Byproduct</b>	<b>How it is formed?</b>	<b>Health Effects</b>
Trihalomethanes	Trihalomethanes occur when naturally-occurring organic and inorganic materials in the water react with the disinfectants, chlorine and chloramine.	Some people who drink water containing total trihalomethanes in excess of the MCL over many years could experience liver, kidney, or central nervous system problems and an increased risk of cancer.
Haloacetic Acids	Haloacetic acids occur when naturally-occurring organic and inorganic materials in the water react with the disinfectants, chlorine and chloramine.	Some people who drink water containing haloacetic acids in excess of the MCL over many years may have an increased risk of getting cancer.

Regulatory reporting is based on a running annual average of quarterly sample results. The calculated THM and HAA averages were below the maximum allowable concentrations (MAC) permitted by the MECF. Table 8 provides a summary of 2024 disinfection byproduct sampling.

**Table 8: 2024 Dunnville Drinking Water System DBP Sampling**

Parameter	Sample Date	Sample Results (ug/L)	Annual Average (ug/L)	Regulatory MAC (ug/L)	Exceedance
Haloacetic Acids Dunnville WTP	February 8, 2024	5.3	5.2	80	No
	May 13, 2024	4.7			
	August 9, 2024	5.3			
	November 8, 2024	5.3			
Haloacetic Acids Dunnville Distribution	May 14, 2024	17.7	10.2	80	No
	July 31, 2024	7.8			
	October 31, 2024	5.3			
Trihalomethanes Dunnville WTP	February 8, 2024	6.8	17	100	No
	May 13, 2024	22			
	August 9, 2024	23			
	November 8, 2024	16			
Trihalomethanes Dunnville Distribution	May 14, 2024	31	30	100	No
	July 31, 2024	34			
	October 31, 2024	25			

Note: The first quarter samples for the Haldimand County Distribution system were not taken in 2024. The MECP issued a non-compliance for Haldimand County. Haldimand County created a corrective and preventative action plan that was accepted by the MECP and is currently in place.

Additional sample results for organic and inorganic parameters can be found in the appendices.

## Water Use

### Raw Water

The Dunnville Drinking Water System’s raw water source is Lake Erie. A Permit to Take Water (PTTW) specifies the maximum volume of raw water that can be taken from the water source and conveys MECP site-specific regulatory requirements. When comparing the 2024 maximum raw water flow and the permit limits (*Figure 3*), 75% of Haldimand County’s raw water allotment was available for use.

### PTTW Raw Water - Lake Erie

Maximum: 26,000 m<sup>3</sup>/day

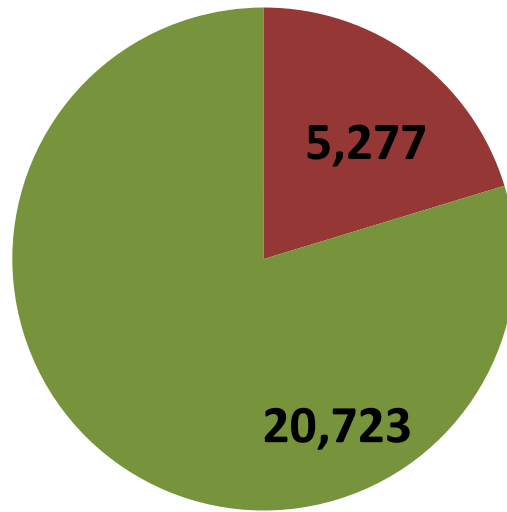

■ 2024 Maximum Daily Flow (m3)    ■ 2024 Available Flow (m3)

### PTTW Raw Water - Grand River

Maximum: 4,500 m<sup>3</sup>/day

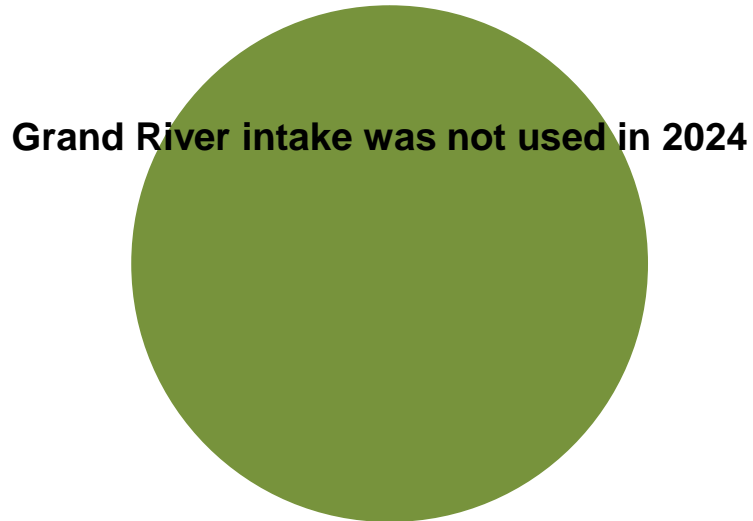

■ 2024 Available Flow (m3)

**Figure 3: Dunnville Permit to Take Water (PTTW) Flow Comparisons**

## Potable Water

As required by Schedule 22 of Ontario Regulation 170/03, Table 9, Table 10 and Figure 4 are intended to provide a summary of potable water supplied by the Dunnville Drinking Water System in 2024.

**Table 9: 2024 Dunnville Drinking Water System Monthly Potable Water Flow Data**

Month	Monthly Total m <sup>3</sup>	Daily Average m <sup>3</sup>	Maximum Day m <sup>3</sup>	Maximum Daily Flow Rate L/s
January	75,002	2,419	2,993	35
February	75,024	2,587	3,335	39
March	78,402	2,529	3,358	39
April	82,048	2,735	3,453	40
May	106,698	3,442	4,624	54
June	105,494	3,516	4,745	55
July	103,256	3,331	4,305	50
August	99,268	3,221	4,215	49
September	93,083	3,088	4,119	48
October	98,674	3,183	4,362	50
November	91,723	3,057	5,747	67
December	94,530	3,049	4,906	57

Figure 3 compares the monthly flows over the last five years at the Dunnville Water Treatment Plant. When comparing the average monthly flows for 2023 and 2024, there was a **2.30% increase** in potable water supplied to the distribution system.

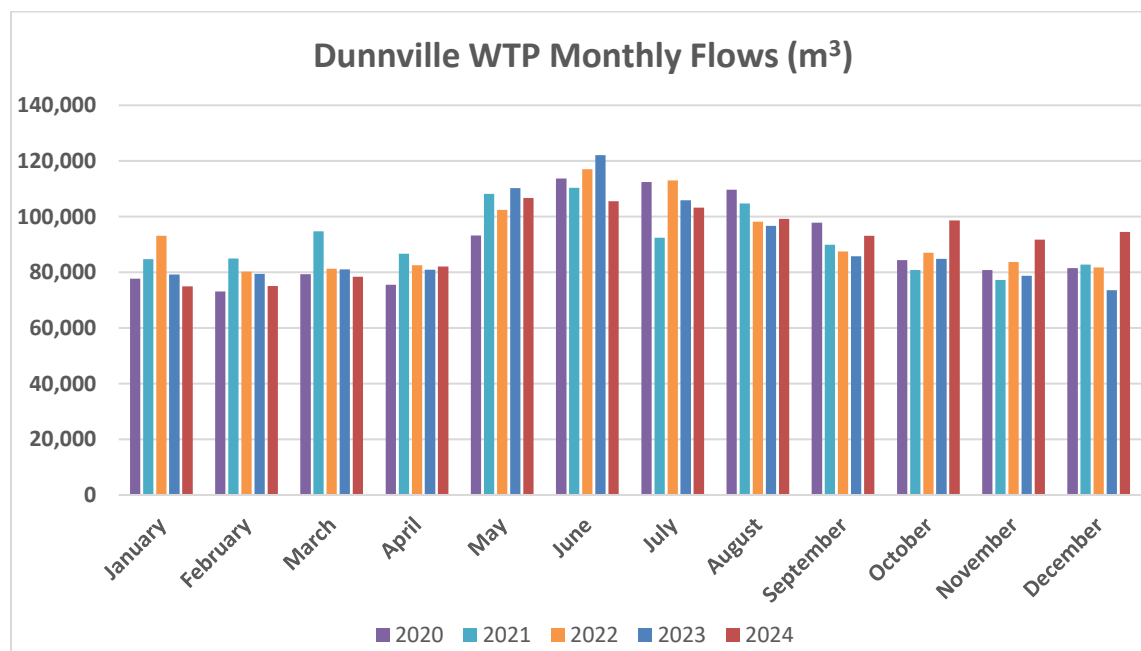

**Figure 3: Dunnville Water Treatment Plant Five Year Monthly Potable Flow Comparison**



According to the Dunnville Water Treatment Plant’s Engineer’s Report, the facility has a rated capacity of 14,500 cubic meters per day. When compared against the maximum daily flow for 2024, the Dunnville Water Treatment Plant is operating at approximately 39.6% of design capacity, however this calculation does not take into account any operational and infrastructure limitations.

**Table 10: Comparison of Rated Capacity and 2024 Maximum Flow Rate**

<b>System and Municipal Drinking Water License</b>	<b>Rated Capacity</b>	<b>Maximum Daily Flow (m<sup>3</sup> / day)</b>	<b>Percentage of Capacity</b>
Dunnville 066-101	14,500 m <sup>3</sup> /day	5,747 m <sup>3</sup> /day	39.6 %

To ensure the water treatment facility is capable of meeting current and projected demands, Haldimand County staff annually review plant capability and performance and update development allocation accordingly.

## Regulatory Compliance

### Adverse Water Quality Incidents

Regulatory compliance requires reporting adverse water quality incidents to the Ministry of Health (MOH) and the Ministry of the Environment, Conservation and Parks (MECP). In all instances, corrective action is initiated to resolve the issue. Over the 2024 period there was adverse water quality incidents to report.

<b>#</b>	<b>Adverse Type</b>	<b>Corrective Action</b>	<b>Status</b>
1	June 12, 2024 Analytical Lab contacted Haldimand County on June 12, 2024 to report a microbiological reading NDOGN for a sample station in the Dunnville Drinking Water system. NDOGN represents a cover of undetermined bacteria.	Flushing of sampling stations and chlorine residual testing was completed.	Resolved

### Annual Drinking Water Inspection

The MECP annually confirms compliance with drinking water legislation by conducting inspections on drinking water systems. All aspects of the drinking water system are reviewed, including treatment equipment, disinfection, training records, and operational data required under the Safe Drinking Water Act, Ontario Regulations 170/03, 169/03 and 128/04. These inspections provide Haldimand County and OCWA an opportunity to review best management practices and work towards continually improving the operation and management of the drinking water systems. Any issues of regulatory non-compliance are identified and corrective actions issued.

The findings for the 2024 annual drinking water system inspection are included in this report. Below is a summary of the key findings for the inspection:

## Dunnville Drinking Water System – DWS# 220003555

There were three non-compliance items identified during the 2024 inspection period. The County received a **96.8%** inspection rating from the MECP.

Haldimand County continues to work closely with regulatory bodies to ensure a continued supply of safe, reliable drinking water to its users. All recommendations have been addressed and communicated to the MECP.

#	Finding Type	Finding	Status
1	Non-compliance	<p>On August 16, 2024, the Ministry was notified that the raw water bacteriological sample taken on August 12, 2024 at the Port Maitland Low Lift had a total chlorine residual of 0.19 mg/L. This was due to a chlorine line being installed.</p> <p>The chlorine pumps were put into service on August 9th and the sample pump was not completely installed by the contractors, leading to taking the August 12th sample from the normally non-chlorinated industry wet well, which now was being chlorinated.</p>	Corrective actions complete by the Operating Authority.
2	Non-compliance	Haloacetic Acid samples were not taken on the 1 <sup>st</sup> calendar quarter of 2024, but were completed in subsequent quarters of 2024	Corrective actions complete
3	Non-compliance	Trihalomethane samples were not taken on the 1st calendar quarter of 2024, but were completed in subsequent quarters of 2024	Corrective actions complete

# Report Availability

This report can be viewed online at:

[haldimandcounty.ca/drinking-water/](https://haldimandcounty.ca/drinking-water/)

Reports can also be obtained upon request at the Haldimand County Administration Building:



## **Cayuga Administration Building**

53 Thorburn St. S

Cayuga, ON

N0A 1E0

For more information on report content, please contact the Haldimand County Environmental Operations Division at:

Email: [wwwops@haldimandcounty.on.ca](mailto:wwwops@haldimandcounty.on.ca)

Telephone: 905-318-5932

# Appendix A

## Inorganic and Organic Sample Results

### Inorganic Parameters

Parameter	Sample Date	Result Value	Unit of Measure	Exceedance
Antimony	March 11, 2024	ND	ug/L	No
Arsenic	March 11, 2024	ND	ug/L	No
Barium	March 11, 2024	21.9	ug/L	No
Boron	March 11, 2024	17	ug/L	No
Cadmium	March 11, 2024	0.004	ug/L	No
Chromium	March 14, 2024	ND	ug/L	No
Mercury	March 8, 2024	ND	ug/L	No
Nitrate	February 16, 2024 May 1, 2024 August 14, 2024 November 6, 2024	0.228 1.12 0.333 0.135	mg/L	No
Selenium	March 11, 2024	0.13	ug/L	No
Uranium	March 11, 2024	0.005	ug/L	No

ND = Not Detectable (below detection limit)

## Organic Parameters

Parameter	Sample Date	Result Value	Unit of Measure	Exceedance
Alachlor	March 7, 2024	ND	ug/L	No
Atrazine + Metabolites	March 7, 2024	0.01	ug/L	No
Azinphos-methyl	March 7, 2024	ND	ug/L	No
Benzene	March 7, 2024	ND	ug/L	No
Benzo(a)pyrene	March 7, 2024	ND	ug/L	No
Bromoxynil	March 7, 2024	ND	ug/L	No
Carbaryl	March 7, 2024	ND	ug/L	No
Carbofuran	March 7, 2024	ND	ug/L	No
Carbon Tetrachloride	March 8, 2024	ND	ug/L	No
Chlorpyrifos	March 7, 2024	ND	ug/L	No
Diazinon	March 7, 2024	ND	ug/L	No
Dicamba	March 7, 2024	ND	ug/L	No
1,2-Dichlorobenzene	March 8, 2024	ND	ug/L	No
1,4- Dichlorobenzene	March 8, 2024	ND	ug/L	No
1,2- Dichloroethane	March 8, 2024	ND	ug/L	No
1,1- Dichloroethylene	March 8, 2024	ND	ug/L	No
Dichloromethane (Methylene Chloride)	March 8, 2024	ND	ug/L	No
2,4- Dichlorophenol	March 8, 2024	ND	ug/L	No
2,4- Dichlorophenoxy acetic acid (2,4-D)	March 8, 2024	ND	ug/L	No
Diclofop-methyl	March 13, 2024	ND	ug/L	No
Dimethoate	March 13, 2024	ND	ug/L	No
Diquat	March 13, 2024	ND	ug/L	No
Diuron	March 13, 2024	ND	ug/L	No
Glyphosate	March 7, 2024	ND	ug/L	No
Malathion	March 7, 2024	ND	ug/L	No
MCPA	March 7, 2024	ND	ug/L	No
Metolachlor	March 7, 2024	ND	ug/L	No
Metribuzin	March 7, 2024	ND	ug/L	No
Monochlorobenzene (Chlorobenzene)	March 13, 2024	ND	ug/L	No
Paraquat	March 13, 2024	ND	ug/L	No
Pentachlorophenol	March 13, 2024	ND	ug/L	No
Phorate	March 7, 2024	ND	ug/L	No
Picloram	March 7, 2024	ND	ug/L	No
Prometryne	March 7, 2024	ND	ug/L	No
Simazine	March 7, 2024	ND	ug/L	No
Terbufos	March 7, 2024	ND	ug/L	No
Tetrachloroethylene	March 8, 2024	ND	ug/L	No
2,3,4,6- Tetrachlorophenol	March 12, 2024	ND	ug/L	No
Total PCBs	March 7, 2024	ND	ug/L	No
Triallate	March 7, 2024	ND	ug/L	No
Trichloroethylene	March 13, 2024	ND	ug/L	No
2,4,6- Trichlorophenol	March 12, 2024	ND	ug/L	No
Trifluralin	March 7, 2024	ND	ug/L	No
Vinyl Chloride	March 8, 2024	ND	Ug/L	No

ND = Not Detectable

## Microcystin Sample Results

Parameter	Sample Date	Lake Erie raw water results	Grand River raw water results	Treated Water Results	Unit of Measure	Exceedance
Microcystin	June 5, 2024	0.1	0.1	0.1	ug/L	No
	June 12, 2024	0.1	0.1	0.1		
	June 19, 2024	0.1	0.1	0.1		
	June 26, 2024	0.1	0.1	0.1		
	July 3, 2024	0.1	0.1	0.1		
	July 10, 2024	0.1	0.1	0.1		
	July 17, 2024	0.1	0.1	0.1		
	July 24, 2024	0.1	0.1	0.1		
	July 31, 2024	0.1	0.1	0.1		
	August 7, 2024	0.1	0.1	0.1		
	August 14, 2024	0.1	0.1	0.1		
	August 21, 2024	0.1	0.1	0.1		
	August 28, 2024	0.1	0.1	0.1		
	September 4, 2024	0.1	0.1	0.1		
	September 11, 2024	0.1	0.1	0.1		
	September 18, 2024	0.1	0.1	0.1		
	September 25, 2024	0.1	0.1	0.1		
	October 2, 2024	0.1	0.1	0.1		
	October 9, 2024	0.1	0.1	0.1		
	October 16, 2024	0.1	0.1	0.1		
	October 23, 2024	0.1	0.1	0.1		
October 30, 2024	0.1	0.1	0.1			

ND = Not Detectable